

# And You Thought All B's Were The Same!

This information came from sales literature I have, which does not cover every model. Any mistakes were free so don't complain; just let me know so corrections can be made.

102 with flush

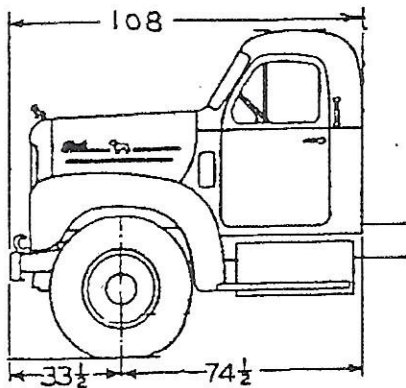

## Most common cab

Flat Back Cab with standard nose  
Used on B-20, 30, 31, 33, 37, 41, 42, 421, 422, 426, 4226, 43, 45, 47, 50, 53, 60, 61, 613, 615, 62, 63, 633, 68, 70

102 with extended bumper

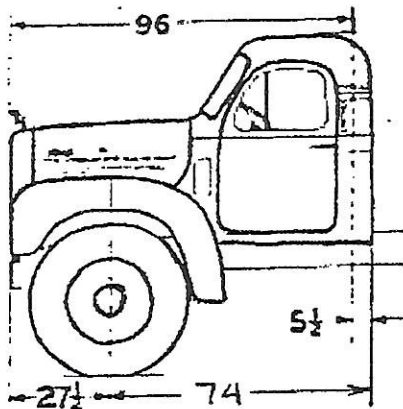

Contour Cab with standard nose  
Used on B-42, 422, 60, 61, 68, 70, 615

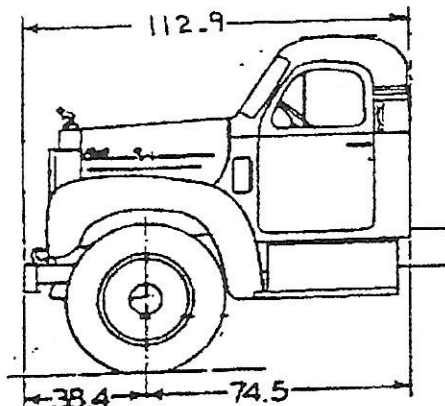

Flat Back Cab with external B-80's style radiator and shutters.  
Used on B-61 SE and B-613 SE (Export)

99 with extended bumper

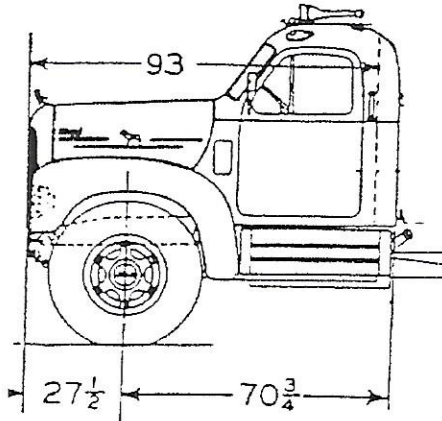

Contour Cab with short nose  
Fenders are 3" shorter than standard  
Used on B-44, 64, 65, 653

95 with flush bumper

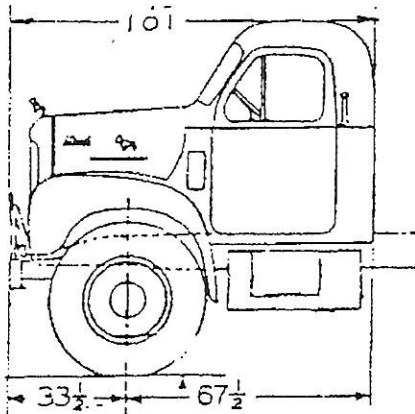

Flat Back Cab with shorter nose  
Fenders are 7" shorter than standard  
Notice the back of the fenders  
Used on B-46, 462, 67, 673, 57

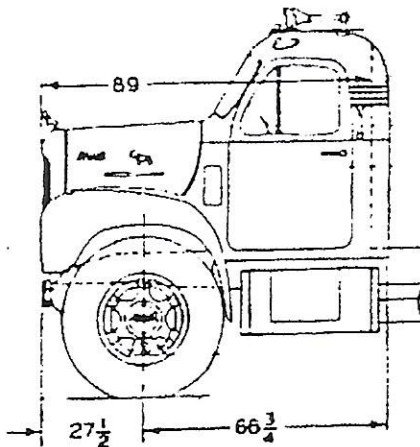

Contour Cab with shorter nose  
Notice the same fenders as the cab  
above  
Used on B-66, 67, 673

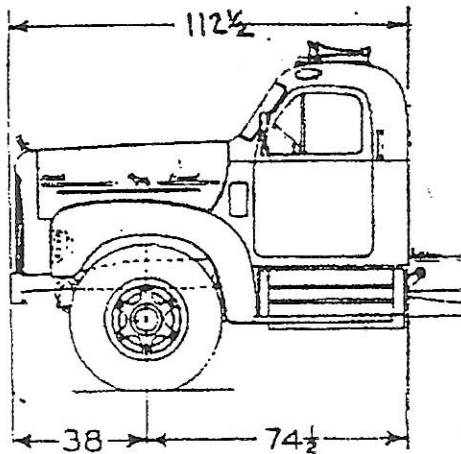

Flat Back Cab with long nose  
 Notice the radiator extends past  
 fenders  
 Used on B-71

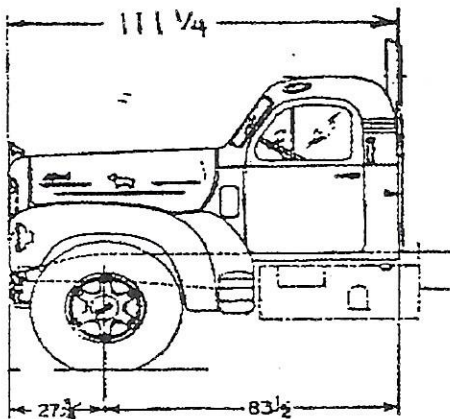

Flat Back Cab with long nose  
 Notice the extensions between the  
 fender and cowl leg.  
 Used on B-72, 73, 733, 75, 753, 755,  
 77, 773

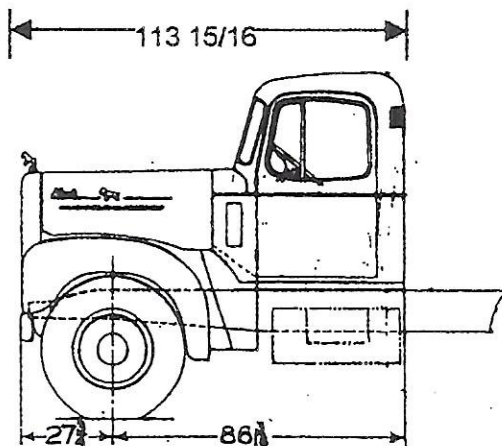

L cab with long nose  
 Used on B-72, 73, 733, 75, 753,  
 755, 77, 773

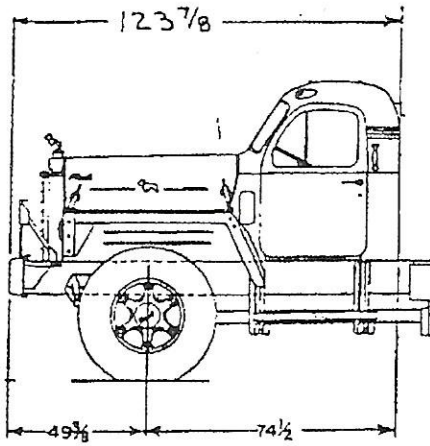

Flat Back Cab with long nose  
Note military style fenders  
Used on B-80, 81, 813, 8136, 815, 83,  
833, 85, 853, 87, 873